

CONNYLACROSSE

2018 LIGHTNING BOYS' LACROSSE RULES of PLAY

In situations that are not directly addressed in these Lightning Rules, the 2018 CONNY Senior & Junior Boys Rules of Play shall apply.

These rules apply to "travel" Lightning games between member programs, but can also serve as guidelines for "in-house" play within member programs.

CONNYP LIGHTNING BOYS' GAME FORMAT SUMMARY and EQUIPMENT

- Small sided play - 8 V 8 (7 field players plus a goaltender) - Now 8v8
- 60-70 x 35-45 YARD FIELD, ADJUSTABLE FOR LOCAL CONDITIONS
- GOALS 40-50 YARDS APART, ADJUSTABLE FOR LOCAL CONDITIONS
- 9' RADIUS GOAL CREASE; 6'x 6' GOALS; 5'x5; 4'x4' AND 6' WIDE x 4' HIGH OPTIONS
- HELMETS, SHOULDER PADS, ARM PADS, LACROSSE GLOVES, MOUTH GUARDS, PROTECTIVE CUPS REQUIRED
- 37"-42" LENGTH STICKS; NO LONG STICKS PERMITTED
- REGULAR LACROSSE BALLS
- 10-MINUTE RUNNING TIME QUARTERS; 2-MINUTES BETWEEN QUARTERS; 5-MINUTE HALFTIME or 25-minute running time halves; 5-minute halftime
- ROTATIONAL SUBSTITUTION STRONGLY RECOMMENDED (SEE RULE 4.21 SUBSTITUTIONS PROCEDURES)
- NO TEAM TIME-OUTS
- NO OVERTIME

CONNYP LIGHTNING BOYS' RULES OVERVIEW

- NO BODY CHECKING BUT LEGAL HOLDS & PUSHES AND INCIDENTAL CONTACT (E.G., BOXING OUT) ARE ALLOWED
- ONLY STICK CHECKS PERMITTED ARE (1) LIFT CHECKS (2) POKE CHECKS (3) DOWNWARD STICK CHECKS INITIATED BELOW BOTH PLAYERS' SHOULDERS
- FACE-OFFS WITH 2 PLAYERS RELEASING FROM WING AREA FOR EACH TEAM
- PENALIZED PLAYER FOR PERSONAL FOULS LEAVES FIELD, BUT NO MAN DOWN DEFENSE/EXTRA MAN OFFENSE
- Fast break is awarded to the non-penalized team
- Two pass rule in the offensive side of the field before shooting
- 5 or 6 goal lead and no face-off

TIERING TEAMS

- It is critical that all CONNY member programs properly tier their Lightning teams
- You should indicate age/grade band, skill level, number of players per team
- Reminder: you are playing the 8v8 format; adjustments can be made for fewer teams but CONNY is no longer sanctioning full field or 10v10 at this level

Eligibility: Students in the Third or Fourth Grade. CONNY strongly recommends single-grade teams, but if a member program needs to group two grades together, it should strive at scheduling to limit the maximum age difference between players in any Lightning game to no more than twenty-four (24) months.

OPTIONAL ADDITIONAL QUALIFICATION AT LOCAL PROGRAM'S DISCRETION:

Age 10 or Under on the September 1st of the year preceding the start of the CONNY season (i.e., born 9/1/2007 or later for 4th Graders and 9/1/2008 for 3rd Graders during the 2018 season).

2018 CONNY Lightning Boys' Lacrosse Rules of Play

Rule 1-The Game, Field, and Equipment

1.1 The Game: The purpose of each team is to score by causing the ball to enter the goal of its opponent and to prevent the other team from securing the ball and scoring.

1.2.1 The Field Measurements: The playing field shall be rectangular, 60-70 yards in length and 35-45 yards in width. The boundaries of the field shall be marked with contrasting colored lines so that boundaries are easily identifiable. All lines on the field shall be between 2 - 4 inches in width.

NOTE: If marked/painted lines cannot be added to create a reduced field, especially one laid out across a standard artificial turf field, (e.g., center spot or X, wing area lines, defensive area lines, "sidelines" for a field across the middle of a standard field), low profile athletic cones, disks, or other markers such as tape that do not present a safety hazard may be used.

A popular option is to play small-sided lacrosse across a standard 110 yard by 60 yard men's field, separated into two or three reduced size fields:

- Two reduced size fields may be bounded by the standard field end lines, sidelines, and defensive-area lines, yielding two 60 by 35 yard reduced size fields. In this instance, the goals would be centered on the standard field goal area lines (making them 10 yards from the end lines). Painted or imaginary wing area lines would be 5 yards from the sideline, extending 5 yards either side of the center line.
- If a third reduced size field is inserted across the middle of the standard full sized field, it should be 60 by 30 yards, with 5-yard bench/buffer areas between it and the other two fields. Low profile athletic cones, disks, or other markers such as tape that do not present a safety hazard should be used to mark the sideline.
- Standard 9-foot radius creases should be marked at the midpoint of the standard field's goal area lines, equidistant from the defensive area lines and the end lines, or at the intersections of the standard field center line and wing area lines. When marked/painted creases cannot be applied, use of portable creases is recommended. If portable creases are not available, low profile athletic cones, disks, or other markers such as tape that do not present a safety hazard may be used to delineate the crease.
- **Sample Field:** small-sided play across a standard 110 yard by 60 yard men's field, separated into two reduced size fields. Other configurations are permitted to accommodate local conditions.

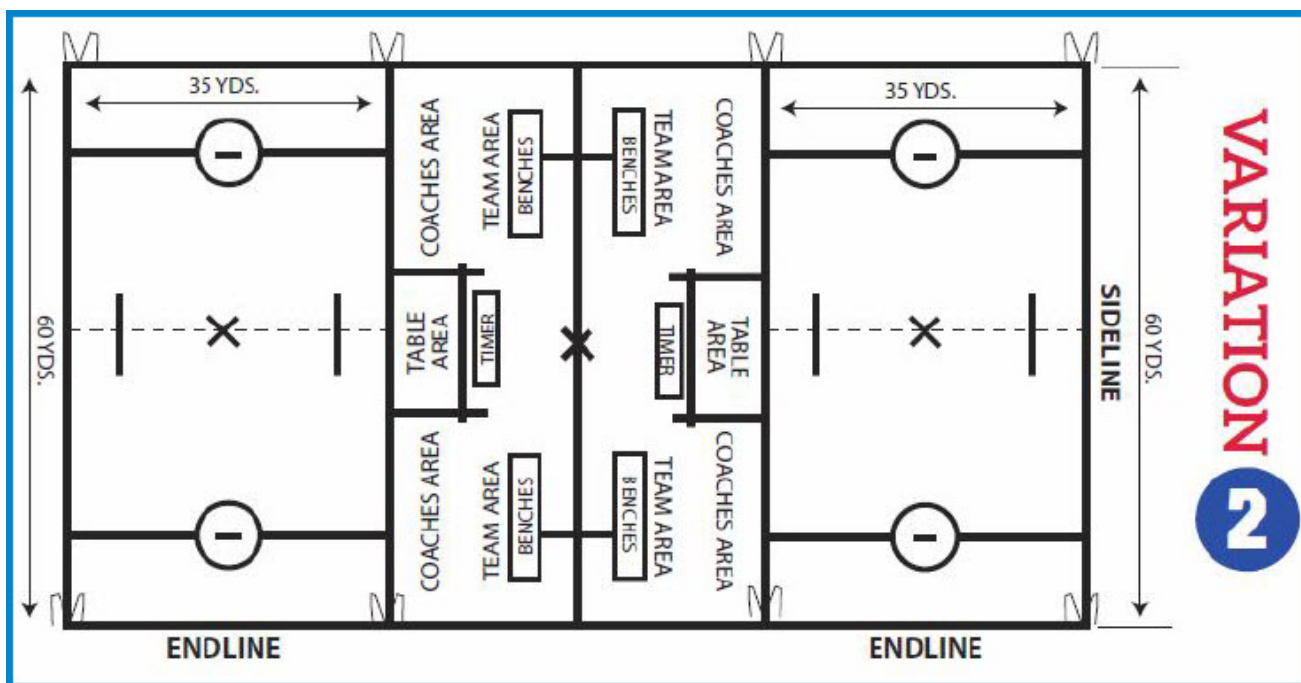

2018 CONNY Lightning Boys' Lacrosse Rules of Play

1.2.6 Center Spot: An approximately a four-inch circle, square or, X shall mark the center of the field.

NOTE: This may be a flat disk.

1.2.1.8 & 1.2.1.9 The team areas (bench and coaches' areas) shall be on the same side of the field extending between the table area and the end line 10 yards parallel to the sideline, 3 to 5 yards from the sideline.

1.3b Goal Creases: The goal creases shall be circular with a radius of 9 feet, and may be painted on the field, marked with flat discs, or a portable crease can be used.

1.3.1 Goals: A 6x6 foot goal with securely affixed netting that will not permit the ball to pass through may be used. Smaller goals (e.g., 4'x4' or 5'x5') or a 2-foot drop net to reduce the height of the goal opening to 4 feet are permitted. If a drop net is used it should be constructed of a material that minimizes rebounds to protect the goalkeeper. The goal shall be centered within the goal crease.

1.5.1 The Ball: Lacrosse balls that meet the current NOCSAE ND049 standard shall be used in all games.

1.6, 1.7, & 1.8 The Crosse Dimensions, Construction, Prohibitions: Field Players Crosse Length: 37" - 42" – NO LONG CROSSES. All other crosse specifications in the CONNY Senior & Junior Rules (Pages 5-6) apply.

1.6, 1.7, & 1.8 - The Goalkeeper Crosse Length: 37"-54". All other goalkeeper crosse specifications in the CONNY Senior & Junior Rules (Pages 5-6) apply.

1.9 (A) Field Player Equipment: All field players shall have (1) A lacrosse helmet that meets NOCSAE ND041 at the time of manufacture, (2) An Intra-oral mouth protector (mouth piece), (3) Protective gloves designed for boy's lacrosse (4) Shoulder pads designed for boy's lacrosse, (5) Athletic cleats or athletic shoes, (6) Arm pads designed for lacrosse, (7) A jersey and shorts of the same color(s) as their teammates, (8) Athletic protective cup.

NOTE 1: The officials are not required to inspect the wearing of a protective cup, and may rely on the coach's certification and/or a player's statement regarding satisfaction of this requirement.

NOTE 2: Rib pads are recommended but not required pieces of equipment.

1.9 (B) Goalkeeper Equipment: All goalies shall have all equipment required for field players except shoulder pads and arm pads, plus (1) A throat protector designed for lacrosse and (2) A goalie chest protector designed for lacrosse.

NOTE 1: Arm pads designed for lacrosse are recommended but not required goalkeeper equipment.

NOTE 2: Shin, knee, and thigh pads may be worn so long as they do not significantly increase the size of the limb protected. Soccer, ice hockey, or field hockey shin pads should be allowed but oversized box lacrosse goalie equipment shall be prohibited. Ice hockey goalie equipment is not permitted.

Rule 2 Game Personnel

2.1.1 - Number of Players: Eight (8) players shall constitute a full team. They shall be designated as follows: Goalkeeper, 2 Defense, 3 Midfield, 2 Attack. A team shall begin the game with at least 8 players, and must have a legally equipped goalkeeper on the field at all times. If both coaches agree, it shall be permitted to play 7v7, 6v6, or 5v5 if team does not have enough players to play 8v8. Full field or 10v10 is not permitted at this level.

If, because of injuries or players out on ejection fouls, or otherwise, a team cannot keep the minimum number of players in the game, that team may continue the game with fewer than 8 players, with onside and stalling rules remaining in effect. However, a game shall not continue if a team has fewer than 5 players. The appropriate sponsoring authority shall determine the result of the game in these circumstances.

2018 CONNY Lightning Boys' Lacrosse Rules of Play

When an official scorebook lineup is used, the players shall be listed from top to bottom as "Attack," "Midfield," "Defense" and "Goalkeeper." The first attack player listed is officially the in-home. All players shall be listed by name, position and number in the official scorebook and shall be listed before the start of the game. The In-Home shall be a starter in the game. In most cases a scorebook is not used and score is kept on the field by the official(s).

2.1.3 Coaches: Coaches are not permitted on the field of play in Lightning play. They shall stay confined to their designated coach's area on the sideline.

2.1.5 Officials : At least one certified official is required. In addition to the required certified official, apprentice officials are permitted (i.e., high school or Senior youth age officials in training).

2.7 Timekeeper : The head coaches shall designate a timekeeper. In the absence of a timekeeper, the certified official on the field shall assume all timing responsibilities..

NOTE: The duties of a timekeeper can be found in Rule 2 Section 7 of the Senior & Junior Rules.

2.8 - Score Keeper: The duties of the scorekeeper shall be in accordance with Rule 2.8 of the Senior & Junior Rules.

Rule 3 Time Factors

3.1- Length of the Game: A competition will consist of (4) 10-minute running time quarters, with a 2-minute break between quarters and a 5-minute half time or (2) 25-minute running time halves with a 5-minute half time.

3.4 – Overtime: Overtime shall not be played in the Lightning Division.

Rule 4 Play of the Game

4.1 Coin Toss: A coin-toss will be used to determine first alternating possession or choice of goal to defend to start the game.

4.2 Player Line-up: Before the start of play the official shall bring all the players on both teams in lines facing each other at the center of the field, with their left sides toward the goal they are defending, and explain any special ground rules, emphasize safety, fair play, and sportsmanship. After the lineup, all the players other than the starters will return to their team areas.

4.3 Facing Off: Play shall be started at the beginning of each period and after each goal by facing the ball at the Center Spot. The official conducting the faceoff will follow procedures specified in Rule 4, Section 3, Article 3 of the 2018 CONNY Senior & Junior Boys Rules except for the EXCEPTIONS listed under Rule 4, Section 3 Article 1 of those Rules.

4.4 Positioning of players and starting play: When a team has all of its players on the field, it shall place one player at the center of the field and shall confine its goalkeeper to his respective crease. Two other players will position themselves behind it's own Goal Line Extended (GLE). Two players will be in the offensive half of the field area positioned behind GLE. Two players from each team will position themselves in the wing area.

When the whistle sounds to start play, the players in the wing areas shall be released. All other players are confined to their areas until a player of either team has gained possession of the ball, the ball goes out of bounds, the ball crosses the defensive-area line, a whistle stops play for a time-serving foul or a whistle restarts play after a non-time-serving foul; when any of these events occur, the faceoff has ended.

2018 CONNY Lightning Boys' Lacrosse Rules of Play

During the faceoff in all situations, there must be three players in the defensive area and two players in the offensive area. Exception: When a team is down to five available players, a player may come out of his defensive area to take the faceoff but must remain onside.

4.5. Two Attempted Passes Required on Offense Before Shooting at the Goal: Once a team has the ball in the offensive half of the field, in order to be able to shoot on the goal, the offensive team has to keep the ball in that zone and attempt two passes before they can shoot; if the passes are not completed cleanly in the air (dropped and recovered), or if the passes are bounced yet caught, or if during the two attempted passing requirement the offensive team momentarily loses possession in the zone but regains possession in the zone, the two attempted pass rule remains in effect. This rule is suspended for a fast break due to a penalty infraction.

4.6 Out of Bounds and ball possession: Play shall be stopped immediately when the ball goes out of bounds. On a shot that goes out of bounds, possession is awarded to the team of the in-bounds player closest to location of the ball when it went out. When the ball goes out of bounds for any other reason other than a shot, it is awarded to the team that did not touch the ball last.

4.7 Ball Caught in Cross or Equipment : If at any point the ball becomes stuck in a players crosse the play shall stop immediately and award the ball to the opposing team.

Note: Neither situation above applies to a designated goalkeeper if he is within his goal-crease area at the time the ball becomes stuck. In this case, a defensive player shall be awarded the ball laterally outside the goal area.

4.8 Goal Scored : A goal is scored when a loose ball passes completely over the goal line and into the goal.

4.8.1 Goal Not Scored

- (a) When the ball crosses the goal line, after the time of a period has expired,
- (b) A player from the attacking team has committed a foul,
- (c) When an attacking team has more players on the field than are legally allowed,
- (d) The goal scorer's stick is found to be illegal,
- (e) Offensive player steps in the crease as the ball is being shot,
- (f) The ball is directed to the goal by something other than a crosse.

4.10 – Offside – A team is considered offside when it has more than five field players in its offensive half of the field (between the center spot and the end line), or more than five players in its defensive half of the field (between the center spot and the end line).

NOTE: Since there is typically no actual midfield line, but only the center spot for reference, players that go slightly off sides should be reminded to return to the correct end of the field.

4.15 Body Checking – NO BODY CHECKING. Any overt (obvious) collision should be enforced as an illegal body check. See Rule 5.3.

Examples of permitted body contact are:

- (a) Legal holds
- (b) Legal pushes
- (c) Positioning oneself against an opponent to gain possession of a loose ball (boxing out)
- (d) Defensive positioning to redirect an opponent in possession of the ball
- (e) Incidental contact

2018 CONNY Lightning Boys' Lacrosse Rules of Play

4.16 Checking With Crosse - In all cases, stick checks must be made with two hands on the crosse and to the crosse of an opponent or his gloved hand on his crosse. An opponent must be in possession of the ball or within 3 yards of a loose ball. Only checks with the crosse listed below are legal:

- (a) Lift the bottom hand or the head of the stick, whichever is below the chest area.
- (b) Poke the bottom hand or the head of the stick, whichever is below the chest area.
- (c) Downward check initiated from below both players' shoulders.

4.18 Goal-Crease Privileges and 4.19 Goal-Crease Prohibitions: No offensive player may enter the crease at any time. Offensive players may reach their stick into the crease for the sole purpose of collecting a loose ball. Defensive players are allowed to be in or pass through the crease as long as they are not in the crease with the perceived intention of blocking a shot. The only players that can attempt to block a shot is a legally equipped goalkeeper. Additionally, no opposing player shall make contact with the goalkeeper or his crosse while he is within the goal-crease area.

4.21 Substitutions Procedures: CONNY believes that Lightning players should play a variety of positions and NOT focus on one position exclusively. Therefore, CONNY strongly recommends *rotational substitution* of field players: i.e., at the first substitution, each team sends two new players in on defense, the two previous defenders move to midfield with an additional player, two middies move to attack, and the original attack goes to the sideline. Both teams repeat this process at each substitution interval. Substitution shall occur after each goal is scored, and may occur during other dead ball situations. Goalkeepers change between the quarters or at halftime. No live ball "on-the-fly" substitutions are permitted.

NOTE 1: If there is an excessively long period of time without scoring or other dead ball situation (e.g., greater than 2 minutes, agreed by both head coaches before the game), play shall be suspended at the first available stopping point to allow rotational substitution of field players. The team entitled to possession of the ball at the stoppage will retain possession after the stoppage. Coaches can request an Official's timeout (see 4.24) if there is a long period of play where this is no stoppage in play on the field.

4.22 - Restarts following a stoppage of play: Restarts following a timeout shall be nearest the spot where the ball was at the time the whistle was blown or if that the ball is within fifteen yards of the goal, it shall be restarted laterally five yards from the sideline nearest to the spot of the ball at the time of the whistle.

4.23 - Change of goal: Teams will change goals between quarters (or halves).

4.24 Official's Timeouts : An official may suspend play at his discretion. If a player loses any of his mandatory personal equipment in a scrimmage area or a player is apparently injured, play shall be suspended immediately. An official may also suspend play if there has been a long period without a stoppage of play and player substitutions should take place.

4.25 Timeouts: There are no team timeouts permitted and the clock shall only stop in the event of injury or at the official's discretion. Injured players must leave the field until the next scheduled substitution and shall be replaced by another player.

4.30 Alternate Possession - When the officials cannot determine which team should be awarded the ball, possession shall alternate or when play is stopped while the ball is loose. The referee shall keep track of the alternating possessions.

4.31 Scrum Situation: In the event that a loose ball cannot be quickly picked up due to two or more players in a "scrum," or is "stuck" the official shall stop play and award the ball via Alternating Possession Rules.

2018 CONNY Lightning Boys' Lacrosse Rules of Play

4.33: Excessive Possession (Optional): One of the objectives at this level is to encourage team play, as opposed to purely individual play. Therefore, if both coaches agree or the organizing authority authorizes, a player who withholds the ball from play by continuing to maintain possession of the ball for more than 5-7 seconds, without passing or shooting, will be assessed a technical foul and possession of the ball will be awarded to the opposing team..

Rule 5 Personal Fouls

Personal fouls are those of a serious nature and typically involve a safety concern or a sportsmanship issue.

In keeping with the overarching emphasis on player safety and sportsmanship at the youth level, CONNY expects strict enforcement of the Cross Check, Illegal Body Check, Checks Involving The Head/Neck, Slashing, Unnecessary Roughness, and Unsportsmanlike Conduct rules.

5.3 Illegal Body-Check, 5.4 Checks Involving the Head/Neck, 5.9 Unnecessary Roughness

NO BODY CHECKING is permitted. At this level, any overt (obvious) collision should be enforced as an illegal body check.
Note: Rule 4.15 details all permitted body contact.

5.2 Cross Check & 5.7 Slashing - Any stick check not listed as legal in Rule 4.16 should be enforced as a slash.

Rule 6 Technical Fouls

Technical fouls are those of a less serious nature than personal fouls and include all violations of the rules of the game except those specifically listed as personal or ejection fouls.

6.2 - Crease Violations Any violation of Rules 4.18 or 4.19."

6.5 - Illegal Procedure: includes fouls of a technical nature, such as: (1) A player shall not touch the ball with his hands while it is in play, (2) Throw his crosse, (3) Play without a crosse, (4) Participate in play out of bounds, (5) Substitute illegally, (6) Kick an opponent's crosse. A team shall: (7) Not have more than 7 field players, (8) Not have a properly equipped goalie on the field.

6.11 - Warding Off: A player in possession of the ball shall not use a free hand or arm to hold or push away the stick or body of a defender.

6.12 - Withholding the ball: Players are not permitted to deliberately cover the ball and withhold it from play with their stick or body.

6.14- Goal Crease Counts: A defending player or a goalie who has possession of the ball may not remain in the crease with possession of the ball for longer than four seconds. If so, referee gives ball to offensive team 5 yards from sideline at the goal line extended (GLE).

6.15- Goalkeeper Interference: Any interference with the goalkeeper while they and the ball are in the crease shall be a play-on. If the goalkeeper is unable to gain possession of the ball or complete a pass the goalkeeper's team will be awarded a free clear / possession at the midfield line.

2018 CONNY Lightning Boys' Lacrosse Rules of Play

Rule 7 Penalty Enforcement

In Lightning running time games penalties will also be running time, and will begin with the next whistle resuming play. The running time penalty clock will stop for all official's timeouts (or play stoppages) and at the end of periods.

Personal Foul Enforcement Penalty: If a personal foul is committed while the offended team is in possession of the ball, the Slow-Whistle Technique will be applied, if appropriate, after which the foul will be explained to the offending player who then must leave the field. The ball is awarded to the offended team on a fast-break opportunity, unless a goal has been scored. Personal fouls committed in a loose ball situation or when the offending team is in possession of the ball will result in an immediate stoppage of play, with the foul being explained to the player who then must leave the field and a fast-break opportunity will be awarded to the non-offending team. In either case a substitute will replace the offending player immediately. Penalized player must remain off the field until the next substitutions can be made but the teams remain all even. The penalized player leaves the field for a substitute (teams remain all-even) and must remain off the field until the next substitutions can be made. Play starts again with ball given to one midfield player on the non-penalized team at midfield. The other midfielders from both the penalized and non-penalized team are positioned approximately 10 yards (as directed by the official) behind the midfielder with the ball before play resumes. Also, before play resumes, the attack (on the non-penalized team) and defense in the offensive zone are positioned at goal line extended (also used as the restraining line). The referee starts play with a whistle to begin the fast break awarded to the non-penalized team.

At no time shall either team play with fewer players than their opponent. The offending player may return on the next rotational or whole team substitution after he has completed his penalty time.

The penalty for a personal foul shall be suspension of the offending player from the game for 1, 2, or 3 minutes, depending on the official's judgment of the severity and perceived intent of the personal foul. A body or stick check to the head, neck, or a body check hit to a defenseless player shall be a 2 or 3 minute, non-releasable, personal foul. For clarity, the player who committed the foul would have to remain off the field for 2-3 minutes, even if a goal was scored.

NOTE: The penalty for an exceptionally violent personal foul may be expulsion from the game.

Technical Foul Enforcement Penalty: Technical fouls committed in a loose ball situation or when the offending team is in possession of the ball will result in an immediate stoppage of play, with the foul being explained to the offending player and the ball awarded to the offended team. If the offended team is in possession of the ball, the Slow-Whistle Technique will be applied, if appropriate, after which the foul will be explained to the offending player and the ball awarded to the offended team, unless a goal has been scored.

Appendix

BANTAM PHILOSOPHY (Kindergarten-2nd Grade)

Bantam play shall be instructional and non-competitive. Therefore, CONNY discourages formation of Bantam "travel teams" and permits no recording or publication of scores, no standings, and no post-season tournament leading to a championship at the Bantam level. In order to maximize each player's touches and participation in the play of the game, CONNY advocates that Bantam contests be small-sided (e.g., the Lightning 7-on-7, or smaller) on short fields, typically across a regulation men's field. Teams within a program should be balanced as evenly as possible in terms of age; size; physical, cognitive, and emotional maturity; and ability.